

TOYOTA COROLLA HATCHBACK 2019 - DOOR SILL ENHANCEMENT

Preparation

Part Number: PT413-12192

Kit Contents

Item #	Quantity Req.	Description
1	2	Front Sill Plates
2	1	Rear Right Sill Plate
3	1	Rear Left Sill Plate

Hardware Bag Contents

Item #	Quantity Req.	Description
1		
2		

Additional Items Required For Installation

Item #	Quantity Req.	Description
1		
2		
3		

Conflicts

None

Recommended Tools

Personal & Vehicle Protection	Notes
Special Tools	Notes
MY 2019 Sill Installation Templates	See printed templates at the end of these instructions
Installation Tools	Notes
Lint Free Cloth	
Hard Rubber Hand Roller	1" to 3" wide i.e. Marshalltown E54D, Dynamat 10007 or Embee P/N 54
Special Chemicals	Notes
Cleaner	VDC approved Cleaner

General Applicability

MY19 Corolla Hatchback and newer vehicles

Recommended Sequence of Application

Item #	Accessory

*Mandatory

Vehicle Service Parts (may be required for reassembly)

Item #	Quantity Req.	Description

Legend

 **STOP:** Damage to the vehicle may occur. Do not proceed until process has been complied with.

 **OPERATOR SAFETY:** Use caution to avoid risk of injury.

 **CAUTION:** A process that must be carefully observed in order to reduce the risk of damage to the accessory/vehicle and to ensure a quality installation.

 **TOOLS & EQUIPMENT:** Used in Figures calls out the specific tools and equipment recommended for this process.

 **REVISION MARK:** This mark highlights a change in installation with respect to previous issue.

 **SAFETY TORQUE:** This mark indicates that torque is related to safety.









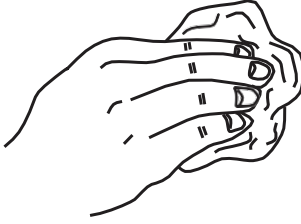

Care must be taken when installing this accessory to ensure damage does not occur to the vehicle. The installation of this accessory should follow approved guidelines to ensure a quality installation.

These guidelines can be found in the "Accessory Installation Practices" document.

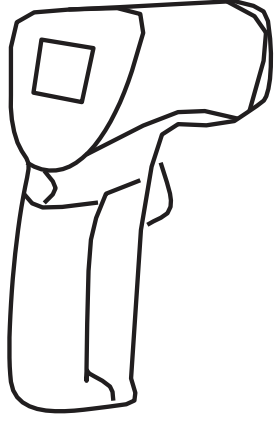
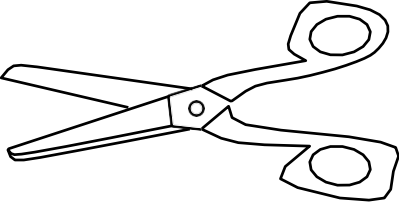
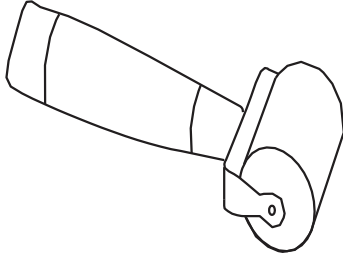
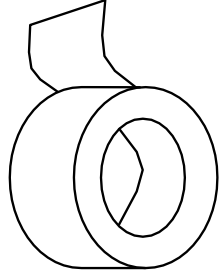
This document covers such items as:-

- Vehicle Protection (use of covers and blankets, cleaning chemicals, etc.).
- Safety (eye protection, rechecking torque procedure, etc.).
- Vehicle Disassembly/Reassembly (panel removal, part storage, etc.).
- Electrical Component Disassembly/Reassembly (battery disconnection, connector removal, etc.).

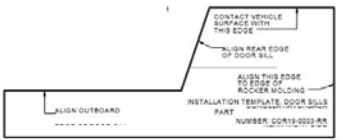
Please see your Toyota dealer for a copy of this document.

<p>A →</p>		
<p>B →</p>		
		
		
		
<p>FRONT AND REAR PAPER TEMPLATES LOCATED ON PAGE 8 AND 9</p>		<p>  = ATTENTION  = VISUAL INSPECTION  = CORRECT </p>
		
		

TOYOTA COROLLA HATCHBACK 2019 - DOOR SILL ENHANCEMENT

Preparation

1



2

⚠️ Apply VDC approved surface cleaner to lint free cloth. Do not spray solution on vehicle surface.



3

Thoroughly clean all four door sills.

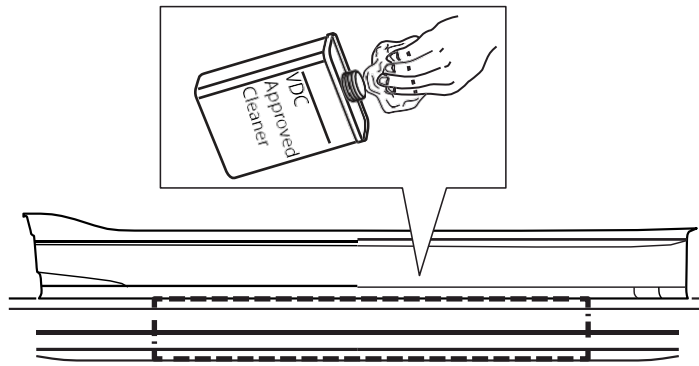

4

⚠️ Dry thoroughly with a lint free cloth.

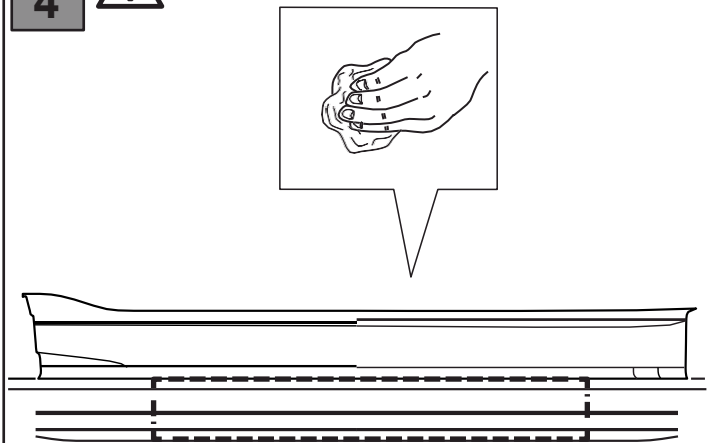

5

⚠️ Wipe the back of all templates to verify cleanliness.

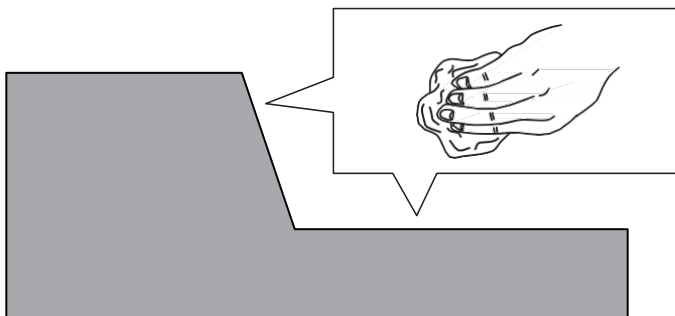

6

60-90° F
15-32° C

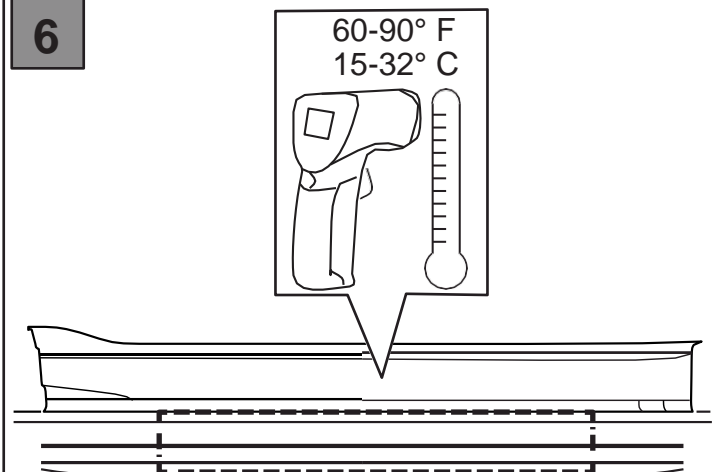

TOYOTA COROLLA HATCHBACK 2019 - DOOR SILL ENHANCEMENT Procedure

7 Install front sill plate. Right side shown.

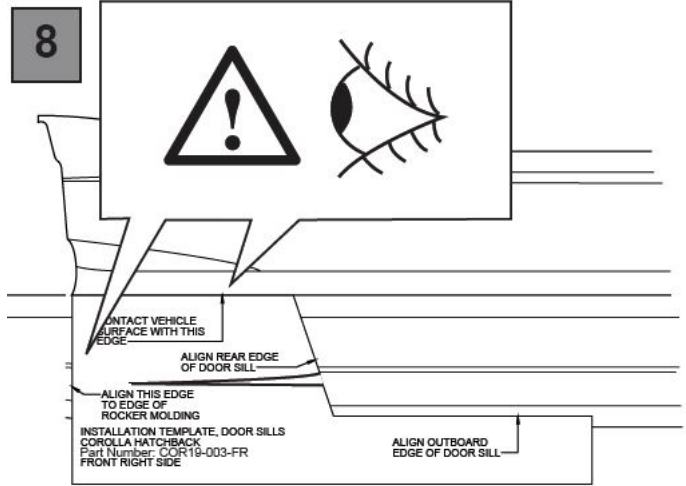
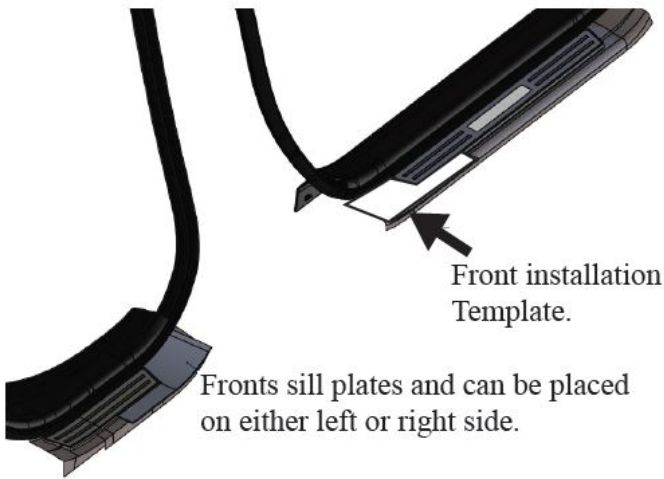

Front Right Shown

9  Template placement is critical to proper installation. Secure with tape as needed.

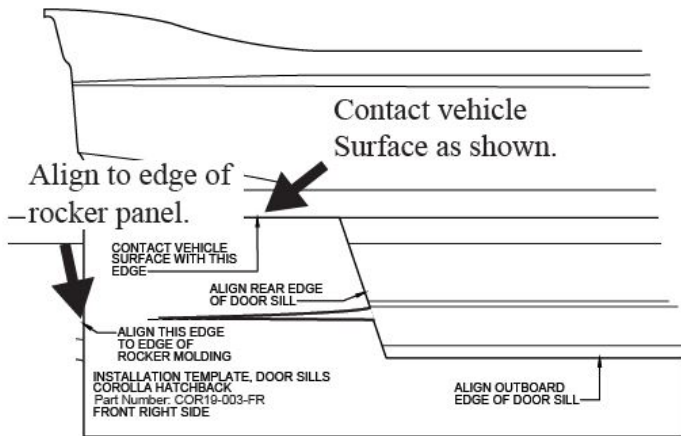

10  Avoid finger contact with adhesive surface.

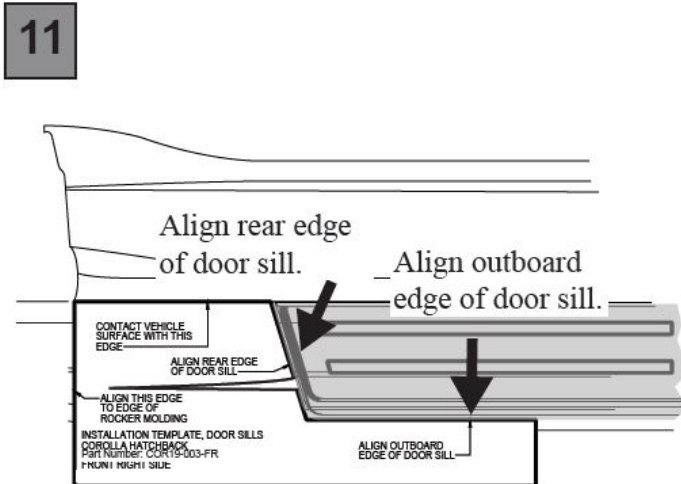
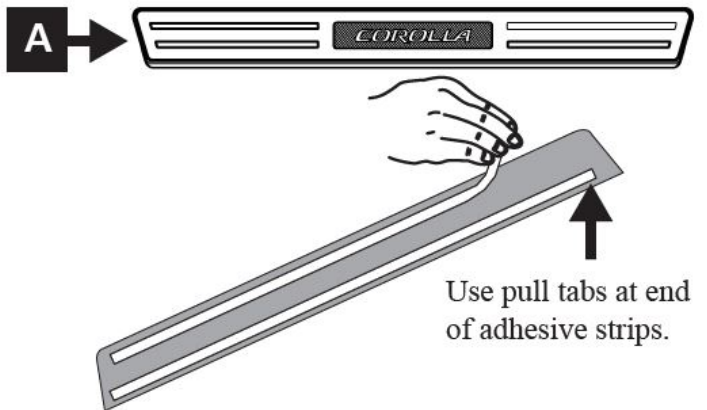

12 Remove template. Place a clean, dry, lint-free cloth over sill plate before applying roller.

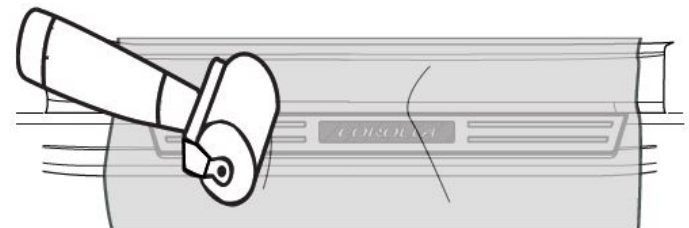

13 Locate template for left hand side.
 Repeat steps 8 through 12.

14 Install rear sill plates. Right side shown.

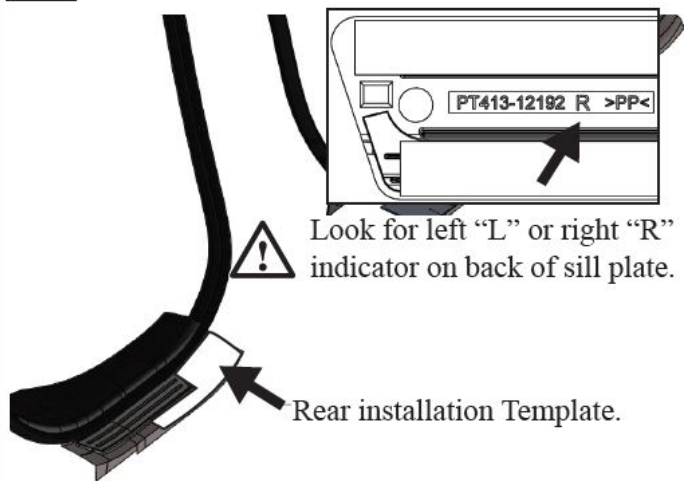

15 Template placement is critical to proper installation. Secure with tape as needed.

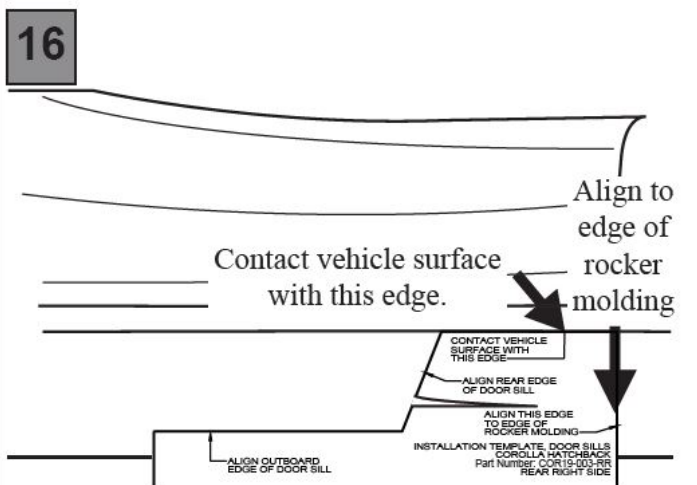
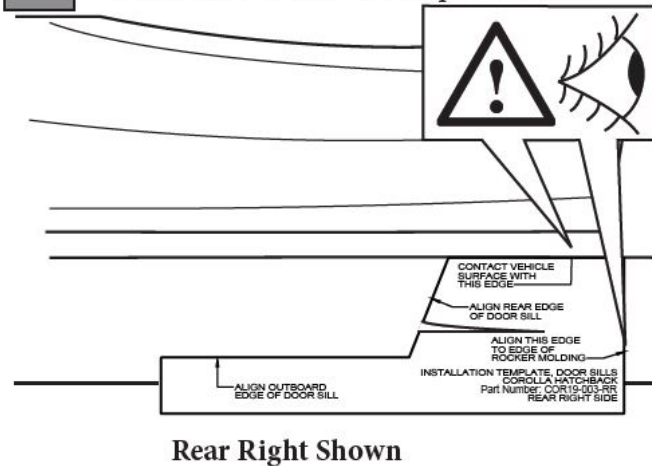

17  Avoid finger contact with adhesive surface.

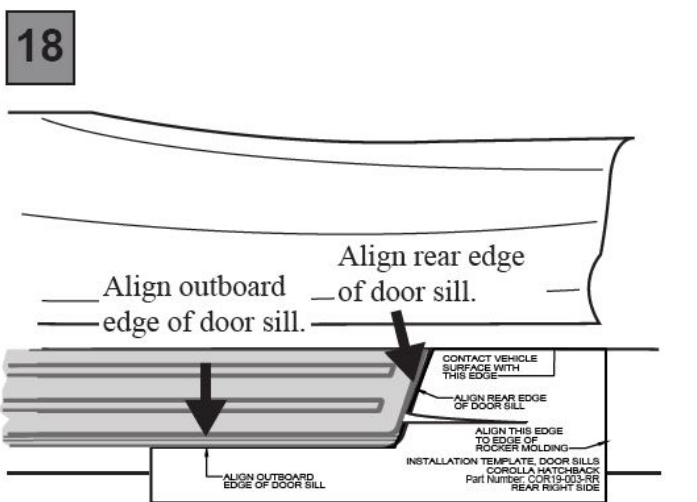
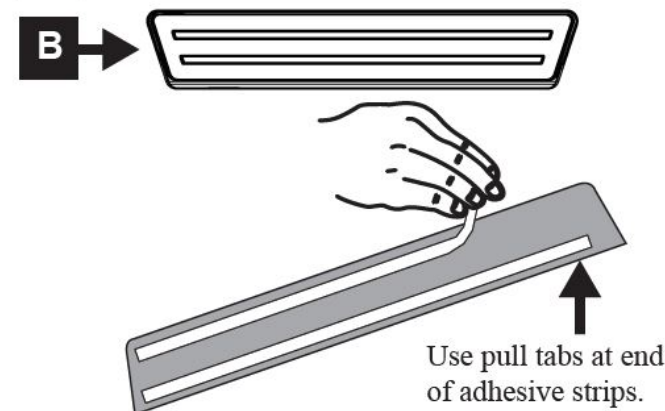

TOYOTA COROLLA HATCHBACK 2019 - DOOR SILL ENHANCEMENT
Procedure

19 Remove template.
Place a clean, dry, lint-free cloth over sill plate before applying roller.

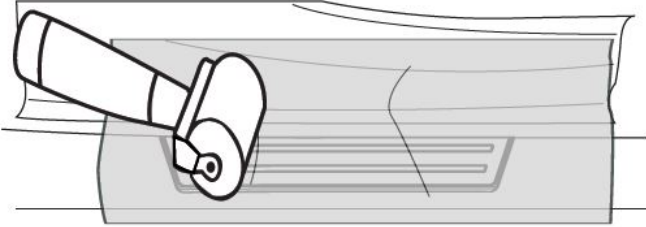

20 Locate template for left hand side.
Repeat steps 15 through 19.

TOYOTA COROLLA HATCHBACK 2019 - DOOR SILL ENHANCEMENT

Checklist -

<u>Check:</u>	<u>Look For:</u>
<p><u>Accessory Function Checks</u></p> <ul style="list-style-type: none"><input type="checkbox"/> Correct part number has been installed.<input type="checkbox"/> Proper rubber roller was used to install part.<input type="checkbox"/> Correct alignment of sill plate.<input type="checkbox"/>	<p>Verify part number on package.</p> <p>Look for loose edges and proper alignment.</p> <p>Verify +/-3mm tolerance for length and +/-2mm for width.</p>
<p><u>Vehicle Function Checks</u></p> <ul style="list-style-type: none"><input type="checkbox"/><input type="checkbox"/><input type="checkbox"/>	
<p><u>Vehicle Appearance Check</u></p> <ul style="list-style-type: none"><input type="checkbox"/> After accessory installation and removal of protective cover(s), perform a visual inspection.	<p>Ensure no damage (including scuffs and scratches) was caused during the installation process. (For PPO installations, refer to TMS Accessory Quality Shipping Standard.)</p>

TOYOTA COROLLA HATCHBACK 2019 - DOOR SILL ENHANCEMENT

Preparation

WHEN PRINTING SET PRINTER TO PRINT
"ACTUAL SIZE"

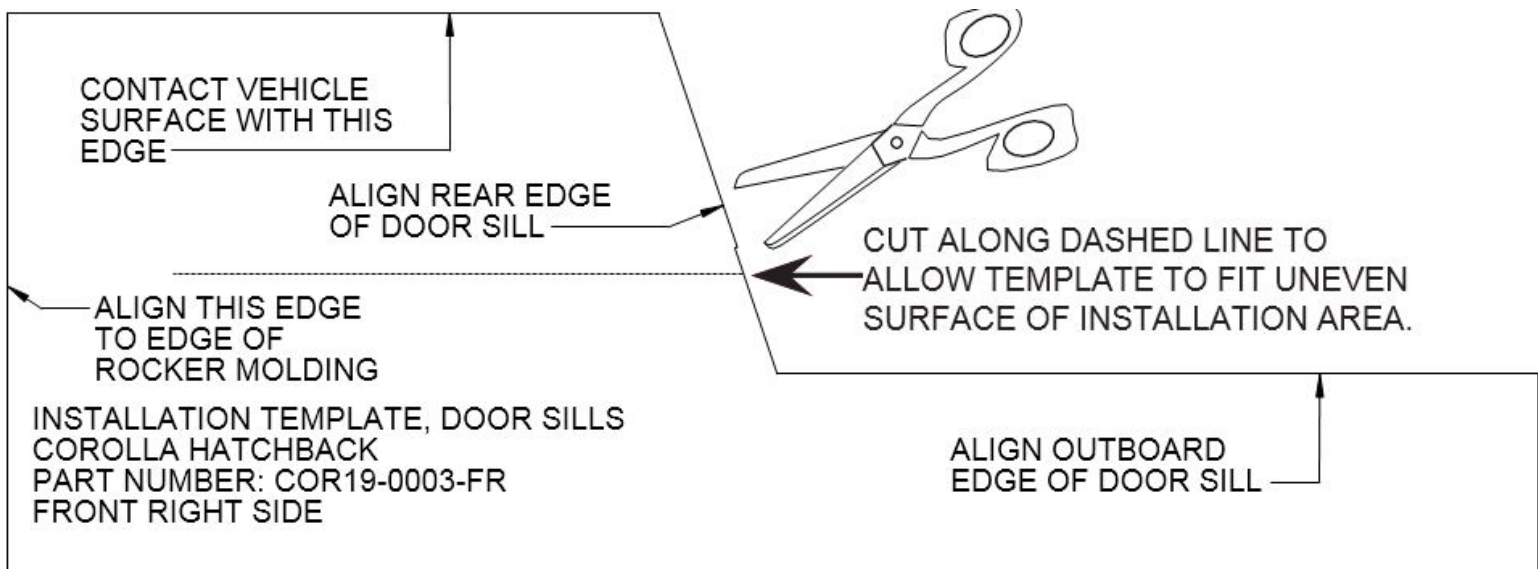
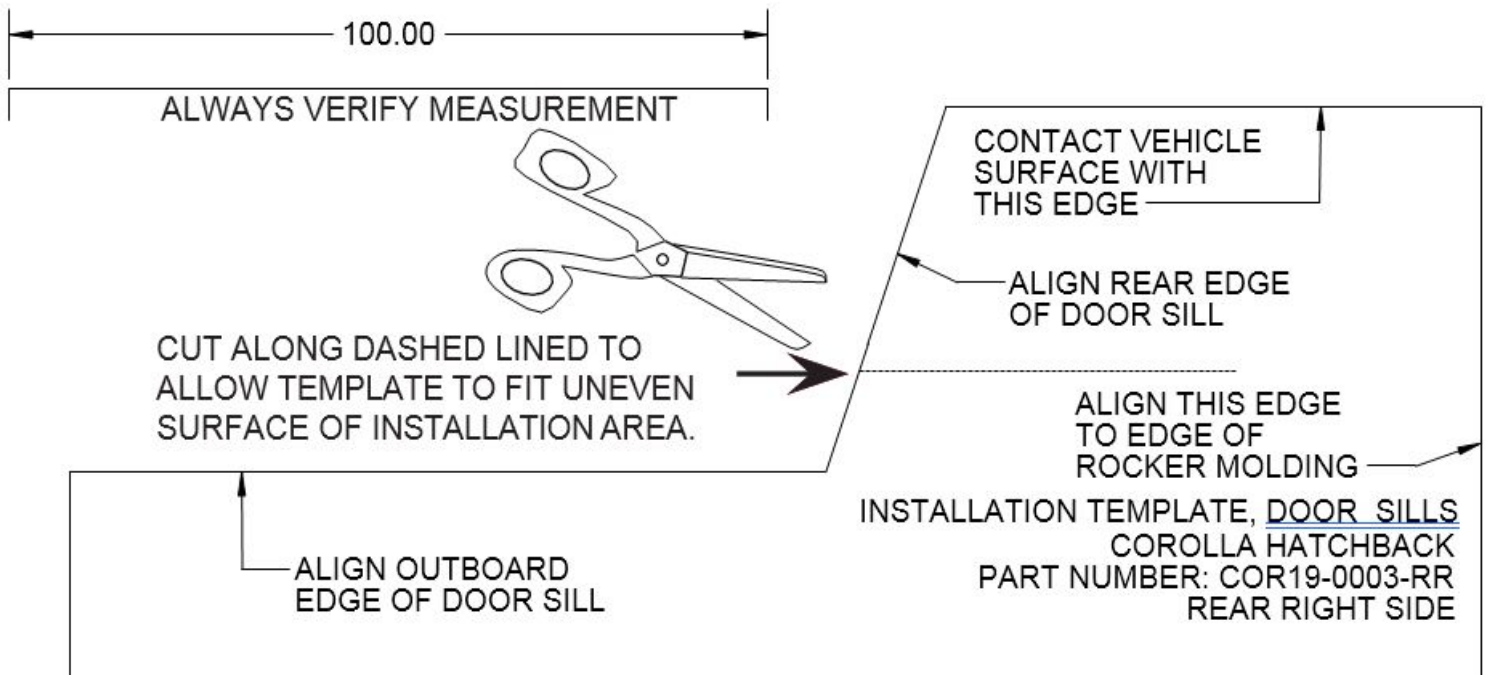

TOYOTA COROLLA HATCHBACK 2019 - DOOR SILL ENHANCEMENT

Preparation

WHEN PRINTING SET PRINTER TO PRINT
"ACTUAL SIZE"

